



MAINTENANCE PROGRAMME

Cars



1.

2.

3.

4.

1.

2.

3.

4.

5.

Vehicle data

Alhambra, Mii, Toledo

1. Vehicle identification number (chassis number)
2. Vehicle type / engine power / gearbox type
3. Engine and gearbox code / paint number / interior equipment
4. Optional extras / PR numbers

Other Models.

1. Vehicle identification number (chassis number)
2. Vehicle type, model, capacity, engine type, finish, engine power and gearbox type
3. Engine code, gearbox code, external paint code and internal equipment code
4. Optional extras and PR numbers
5. Urban cycle consumption (l/100 km)
Out-of-town consumption (l/100 km)
Combined consumption (l/100 km) /
Combined CO₂ emissions (g/km)

Note

- We recommend that you visit a **SEAT Authorised Service** whenever you require any work done on your vehicle.
- SEAT keeps its **Authorised Services** up-to-date on new product developments. They have tools and highly specialised

personnel who can guarantee the safety and performance of your vehicle.

- **Scrupulously following the General Programme for Inspection Services at the SEAT Authorised Services can help you maintain greater value for your vehicle.**

Table of Contents

Service information	4
Vehicle identification data	4
Service type	6
First service	7
Importance of the Maintenance Programme ..	9
Safety notes	9
SEAT maintenance programme	10
Service intervals	10
Other services available	12
Legal Inspection Service	12
Approved spare parts	12
Approved SEAT exchange parts	12
Genuine accessories	12
Paintwork and body service	13
SEAT Service Mobility	13
Warranty	14
Fault-free operation warranty	14
Paintwork and body warranty	14
Records	15
Service receipts	15
Other notes from the Technical Service	
ice	38
Notes	38
Notes	39
Notes	40

Service information

Vehicle identification data

Model:

Vehicle Registration:

Vehicle identification number

Date of vehicle registration or vehicle delivery:

SEAT Official Service:

Service advisor:

Telephone:

Confirmation of receipt of documentation and vehicle keys

The following items were delivered with the vehicle:	yes	no
On-board documentation, including the Maintenance Programme	<input type="checkbox"/>	<input type="checkbox"/>
First key	<input type="checkbox"/>	<input type="checkbox"/>
Second key	<input type="checkbox"/>	<input type="checkbox"/>
Correct working order of all keys was checked	<input type="checkbox"/>	<input type="checkbox"/>
<p>Location: _____ Date: _____</p> <p>Signature of owner: _____</p>		

Service type

LongLife service or service dependent on time/distance travelled?

Depending on your vehicle's technical characteristics either the LongLife service or the service dependent on time/distance travelled will apply. If you do not wish to have the

LongLife service you can choose the service dependent on time/distance travelled. Your specialised workshop has the most recent information about the services and can advise

you on the best type of service for your vehicle, and if there are any additional inspections it requires by law.

How to know which type of service your vehicle requires

LongLife Service:

- your vehicle has LongLife Service provided the vehicle data sticker has the PR number "QI6" (see back) *and if*
- on the »» page 7, the LongLife Service has been marked with a cross.

Service dependent on time/distance travelled:

- your vehicle is serviced according to the time/distance travelled, provided the vehicle data sticker has the PR number "QI1, QI2, QI3, QI4 and QI7" (see back) *, and if*
- On »» page 7, the servicing dependent on time/distance travelled is marked with a cross.

A difference is made in SEAT between services *with* an engine oil change and Inspection services with *no* engine oil change. The service interval display only indicates the dates of the engine oil change and inspection services.

Note

If LongLife oil is not used, the service dependent on time/distance travelled is applied, and the oil must be changed every 15 000 km or every year.

Before delivery, your vehicle was inspected according to factory guidelines. This ensures that driving will be a pleasure from the very beginning.

The agent will provide you with the following information when the vehicle is delivered:

- Running-in
- Changing the brake fluid
- Service intervals, in particular information on what constitutes severe operating conditions » page 10

PR according to markets:

Q11	Service interval display every 5,000 kilometres or every year (fixed)
Q12	Service interval display every 7,500 kilometres or every year (fixed)
Q13	Service interval display every 10,000 kilometres or every year (fixed)
Q14	Service interval display every 15,000 kilometres or every year (fixed)
Q16	Service interval display every 30,000 km or every 2 years (flexible)
Q17	Service interval display every 10 000 miles or every year (fixed)

Note

- **Using diesel fuel with a high sulphur content may significantly reduce the useful life of the diesel particulate filter.**
- **If LongLife engine oil is not used, the service dependent on time/distance travelled then applies. In this case, an oil change service will have to be carried out every 15 000 km or every year.**

Importance of the Maintenance Programme

The Maintenance Programme confirms the date of delivery of your vehicle and thus the beginning of its warranty cover.

The vehicle data that appears in the Maintenance Programme guarantees that the appropriate Genuine SEAT® Parts are installed. This data helps ensure that your car can be repaired without difficulty even after many years of use.

Your specialised workshop will write the details of services that have been carried out in this notebook.

Your Maintenance Programme should be kept in the vehicle with the on-board documentation so that it is at hand whenever you need it.

Please remember to give the Maintenance Programme to the new owner if you sell your car.

The SEAT Service Centre network is equipped with modern workshop technology and well-trained specialists. Many SEAT Service Centres offer different service packages at special prices

Safety notes

All fluids and consumables, such as timing belts, tyres, coolant liquid, engine oil, spark plugs and vehicle batteries are continuously being developed. Therefore, we recommend you take the vehicle to a specialised workshop to have fluids or consumables changed. The SEAT Official Services receive regular up-to-date information about modifications. This is why SEAT recommends you have fluids and other consumables replaced by a SEAT Official Service.

If the vehicle is not serviced or incorrectly/irregularly serviced, the vehicle may break down while driving, leading to serious accident and injury.

- Service work is carried out according to the Maintenance Programme at a specialised workshop.
- Please observe the instructions for use.

Note

- **Only use suitable fluids. Fluids should never be mixed up. This could result in serious faults and engine damage.**
- **SEAT is not responsible for damage to the vehicle as a result of the use of poor quality fuel, inadequate servicing or non-availability of original spare parts.**

- **Spilt brake fluid may pollute the environment. If fluids leak or are spilt, they should be collected and disposed of accordingly.**
- **Regular servicing of your vehicle not only helps to ensure it remains in good working order but also contributes to road safety. Therefore, we recommend carrying out work according to specifications in the Maintenance tables. Your specialised workshop will be delighted to assist you.**

SEAT maintenance programme

Service intervals

General information

To ensure that you have each service carried out on time and that none are forgotten, there is a reminder sticker on the driver side door pillar and a reminder will also be shown via the service interval display on the instrument panel.

The service intervals quoted are for vehicles used under **normal operating conditions**.

However, if the vehicle is used in **adverse conditions**, it may require work before the next established service interval or even between service intervals.

Adverse conditions include:

- the use of fuel with a high sulphur content
- frequent short journeys
- leaving the engine idling for long periods of time (as occurs with taxis)
- driving on dusty roads or in dusty areas
- frequently using the vehicle for towing
- mainly driving in the city, in heavy traffic where it is necessary to continuously brake and start, and

- using the vehicle mainly in the winter

This particularly affects:

- the air filter
- the timing belt
- the engine oil and
- the diesel particulate filter

The service advisor at your specialised workshop will tell you if, due to prevailing conditions, your vehicle will require more frequent work.

Your SEAT Official Service always has the latest available information and will be able to tell you if your vehicle requires any other additional inspections established by law.

The cost of the SEAT service may vary, depending on the vehicle type, equipment fitted, additional work and statutory inspections. Your SEAT Official Service will tell you how much the SEAT service will cost (labour and parts).

Intervals

Service	Service type	
	LongLife service (Flexible)	Service according to time or mileage (Fixed)
Oil change service ^{a)}	According to the flexible service interval display (PR Q16, maximum after 2 years or 30 000 km (20 000 miles) ^{b)}	According to the service interval display (PR Q11, Q12, Q13, Q14 and Q17)» table on page 8
Inspection service ^{a)}	The first service after two years or 30,000 km ^{b)} , then every year or 30,000 km ^{b)}	The first after two years or 30,000 km ^{b)} , and then every year or 30,000 km ^{b)}

^{a)} Under certain circumstances different services can be carried out at the same time (Oil Change and Interval Services in combination with the Inspection Service).

^{b)} Whichever comes first.

Please see the oil specifications given in the Instruction Manual.

LongLife Service

Thanks to the technology used at SEAT, with the **LongLife Service**, an Interval Service only has to be carried out when it is necessary.

The length of the service intervals is also determined by factors such as conditions under which the vehicle is used and personal driving style.

If LongLife engine oil is not used, the service dependent on time/distance travelled then applies. In this case, an oil change service

will have to be carried out every 15 000 km or every year. This also applies if you reprogram the vehicle to the service dependent on time/distance travelled

Note

- In addition to the Inspection Service and Oil Change, additional work must be carried out which is dependent on the time/mileage.
- Your specialised workshop is informed of the work to be completed during each inspection.
- We recommend that you visit a SEAT Authorised Service whenever you require any work done on your vehicle.

- SEAT keeps its Authorised Services up-to-date on new product developments. They have tools and highly specialised personnel who can guarantee the safety and performance of your vehicle.
- Scrupulously following the General Programme for Inspection Services at the SEAT Authorised Services can help you maintain greater value for your vehicle.

Other services available

Legal Inspection Service

The legal inspections must be carried out at the intervals prescribed.

Many countries have legal requirements obliging owners to have their vehicle tested at specified intervals for safety for the user and for other traffic, as well as ensuring that vehicle exhaust emissions meet the countries' regulations. These revisions must be overseen by officially certified centres.

Your SEAT Official Service can advise of the inspections required by law, and can check your vehicle in the course of an Inspection Service. This will save you both time and money.

The SEAT Official Service can also carry out the inspections required by law at the client's request.

Even if you do not wish to take advantage of this service and decide to take your vehicle to an officially certified centre for this check, we recommend that you speak to the manager of your SEAT Official Service first.

This person will be able to inform you of any points that require attention so that your car does not fail the test and have to be re-tested.

Approved spare parts

Genuine SEAT spare parts are designed for your vehicle and approved by SEAT, particularly as regards safety. The workmanship, precision of dimensions and materials of these parts comply exactly with factory specifications. Genuine SEAT spare parts have been designed especially for your vehicle. We therefore recommend that you always use genuine SEAT spare parts. SEAT will not be held responsible for the safety and reliability of parts from other manufacturers.

At SEAT Authorised Service Partners you will generally find the most important genuine SEAT parts. If a part is not in stock, it can usually be obtained quickly.

SEAT Authorised Service Partners provide a warranty for genuine SEAT parts, valid from the date of purchase or fitting. It is therefore advisable to retain the original receipt from the SEAT Authorised Service Partner as proof of the contractual warranty.

Please ask your SEAT Official Service for further information.

The genuine SEAT spare parts warranty can be submitted to **any SEAT Official Service**.

Approved SEAT exchange parts

The approved SEAT exchange parts, conforming to the manufacturer's requirements, constitute an additional service at your disposal, offering you the possibility to replace entire assemblies, the most common being: the lightened engine, gearboxes, cylinder heads, control units, electrical elements, etc.

These are **Approved parts** and as such, share the same approved spare parts warranty as the manufacturer parts.

However, these parts are considerably cheaper as they are factory-reconditioned used parts. Keep the invoice for the approved SEAT exchange parts as proof of the start of the existing warranty.

More information about this may be obtained at the SEAT Official Service.

Genuine accessories

We recommend that you use only Genuine SEAT Accessories and accessories approved by SEAT.

If you wish to equip your car with accessories, you should remember the following points:

We recommend that you use only Genuine SEAT Accessories and approved SEAT Accessories. These accessories are checked for reliability, safety and suitability for your vehicle type. SEAT will not be held responsible for the safety and reliability of parts from other manufacturers.

The SEAT Official Services provides a warranty for Genuine Accessories valid from the date of purchase or fitting. It is therefore advisable to retain the original invoice from the SEAT Official Service as proof of the existing warranty.

More information about this may be obtained at the SEAT Official Service.

The accessories service also offers you expert advice and, if required, fitting by a specialist.

In addition, SEAT Official Services are able to supply car care products and parts subject to natural wear, such as tyres, a battery and light bulbs.

Paintwork and body service

SEAT vehicles are designed in such a way that, in case of bodywork damage, there is only need to replace and paint the parts that have been really affected.

Both operations must be carried out according to the requirements of the manufacturer;

this is an essential condition for conservation of the bodywork and paintwork warranties.

SEAT Service Mobility

You benefit from SEAT Service Mobility advantages and coverage from the time you purchase your new SEAT.

Your new SEAT is automatically covered by SEAT Service Mobility at no extra cost for the first two years after purchase.

If you would like to continue benefiting from the service, you may extend the SEAT Service Mobility as long as you have your Inspection or Maintenance Services done at an Authorised SEAT Dealer.

Your right to the service will be documented in the Inspection and Maintenance Plan when you extend the Mobility Service.

If your SEAT breaks down due to a malfunction or accident, our customer care services will keep you on the road.

Note that the SEAT Mobility Service differs in each country. For further information, check with your SEAT dealer or your SEAT country website.

Warranty

Fault-free operation warranty

SEAT Official Services provide a warranty for the fault-free operation of SEAT vehicles new from the factory. Consult your sales contract, or complimentary or additional documentation provided by your Technical Service where the details of the warranty conditions and the warranty period are accredited. Please ask your SEAT Official Service for further information.

We hope that it is understood that **natural wear** as well as damage caused by the abuse of vehicle performance through inappropriate use or by unacceptable modifications are excluded from the warranty. The warranty is also invalid when the vehicle is damaged by the use of parts and accessories that are not SEAT approved or damage due to ignoring the maintenance and repair requirements.

Paintwork and body warranty

SEAT Official Services provide a warranty that covers the paintwork and bodies of all vehicles purchased from them.

In addition to the warranty conditions for brand new SEAT vehicles (as detailed in the purchase contract, or complimentary or addi-

tional documentation), a defined period warranty is also provided covering paintwork and body rusting:

- The additional warranty on paint faults covers the first 3 years following delivery
- Covered against perforation rusting on the body during the first 12 years following delivery.

However, should this type of damage occur, it will be repaired free of charge for parts and labour by any SEAT Official Service.

Warranty claims will not be accepted in the following circumstances:

- if damage is caused by external influence or carelessness, or
- if the damage to the body or the paint has not been repaired in accordance with the manufacturer-defined requirements, or
- if perforation rusting was caused by the failure to carry out repairs in accordance with the manufacturer's instructions.

If the body is repaired or painted, your Technical Service will certify your warranty against perforation rusting for the repaired sections.

Records

Service receipts

Initial observation

In the following boxes, confirmation will be marked with a cross corresponding to when and which service has or has not been done.

This shows clearly what has been done and helps to prevent misunderstandings.

Service receipts

	YES	NO
LongLife Service:	<input type="checkbox"/>	<input type="checkbox"/>
Service dependent on time/distance travelled	<input type="checkbox"/>	<input type="checkbox"/>
Oil change service	<input type="checkbox"/>	<input type="checkbox"/>
Inspection	<input type="checkbox"/>	<input type="checkbox"/>
Without oil change	<input type="checkbox"/>	<input type="checkbox"/>
With oil change	<input type="checkbox"/>	<input type="checkbox"/>
Additional jobs:	YES	NO
Dust and pollen filter	<input type="checkbox"/>	<input type="checkbox"/>
Air filter	<input type="checkbox"/>	<input type="checkbox"/>
Fuel filter	<input type="checkbox"/>	<input type="checkbox"/>
Spark plugs	<input type="checkbox"/>	<input type="checkbox"/>
Brake fluid	<input type="checkbox"/>	<input type="checkbox"/>
DSG®: oil and filter	<input type="checkbox"/>	<input type="checkbox"/>
ATF	<input type="checkbox"/>	<input type="checkbox"/>
HALDEX clutch (oil)	<input type="checkbox"/>	<input type="checkbox"/>
Gas filter and hoses	<input type="checkbox"/>	<input type="checkbox"/>
Liquid gas filter (paper filter)	<input type="checkbox"/>	<input type="checkbox"/>
Timing belt	<input type="checkbox"/>	<input type="checkbox"/>

Date:

Km/Miles:

Invoice number:

Repair recommendation:

Service carried out by:

Technical Service Stamp

SEAT Service Mobility

Valid from:

to:

SEAT dealer's stamp

Next Service to be carried out

Date:

Km/Miles:

(whichever is first)



Note

We recommend that you visit a SEAT Official Service whenever you require any work done on your vehicle. Scrupulously following the Services (oil, inspection) at a SEAT Official Service can increase the value of your vehicle.

Proof of bodywork check (regarding corrosion)

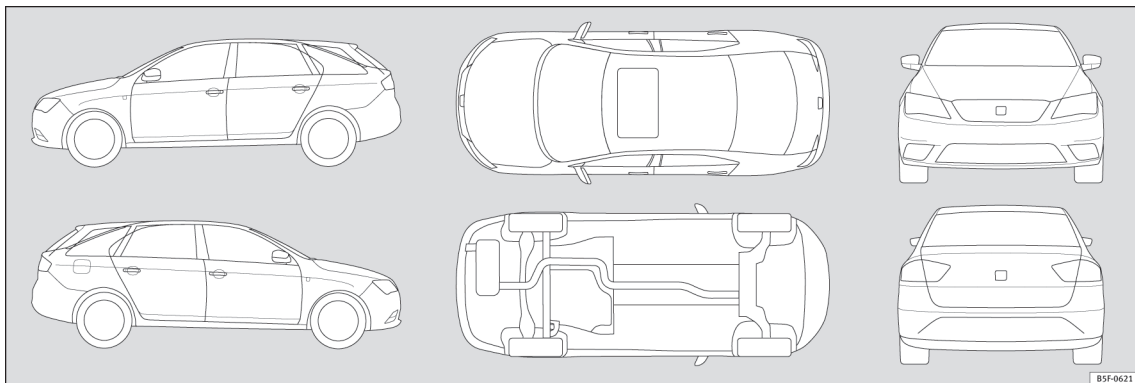

BSF-0621

Fig. 1 For all vehicles and types of bodywork.

Your specialised workshop marks damaged parts in the image with the following symbols:

- × Scratch
- Dent
- Damage to paintwork
- △ Dent from stone

Have any flaws been detected? Yes: No:

Description of flaws:

Technical Service Stamp

Service receipts

	YES	NO
LongLife Service:	<input type="checkbox"/>	<input type="checkbox"/>
Service dependent on time/distance travelled	<input type="checkbox"/>	<input type="checkbox"/>
Oil change service	<input type="checkbox"/>	<input type="checkbox"/>
Inspection	<input type="checkbox"/>	<input type="checkbox"/>
Without oil change	<input type="checkbox"/>	<input type="checkbox"/>
With oil change	<input type="checkbox"/>	<input type="checkbox"/>
Additional jobs:	YES	NO
Dust and pollen filter	<input type="checkbox"/>	<input type="checkbox"/>
Air filter	<input type="checkbox"/>	<input type="checkbox"/>
Fuel filter	<input type="checkbox"/>	<input type="checkbox"/>
Spark plugs	<input type="checkbox"/>	<input type="checkbox"/>
Brake fluid	<input type="checkbox"/>	<input type="checkbox"/>
DSG®: oil and filter	<input type="checkbox"/>	<input type="checkbox"/>
ATF	<input type="checkbox"/>	<input type="checkbox"/>
HALDEX clutch (oil)	<input type="checkbox"/>	<input type="checkbox"/>
Gas filter and hoses	<input type="checkbox"/>	<input type="checkbox"/>
Liquid gas filter (paper filter)	<input type="checkbox"/>	<input type="checkbox"/>
Timing belt	<input type="checkbox"/>	<input type="checkbox"/>

Date:

Km/Miles:

Invoice number:

Repair recommendation:

Service carried out by:

Technical Service Stamp

SEAT Service Mobility

Valid from:

to:

SEAT dealer's stamp

Next Service to be carried out

Date:

Km/Miles:

(whichever is first)

 Note

We recommend that you visit a SEAT Official Service whenever you require any work done on your vehicle. Scrupulously following the Services (oil, inspection) at a SEAT Official Service can increase the value of your vehicle.

Proof of bodywork check (regarding corrosion)

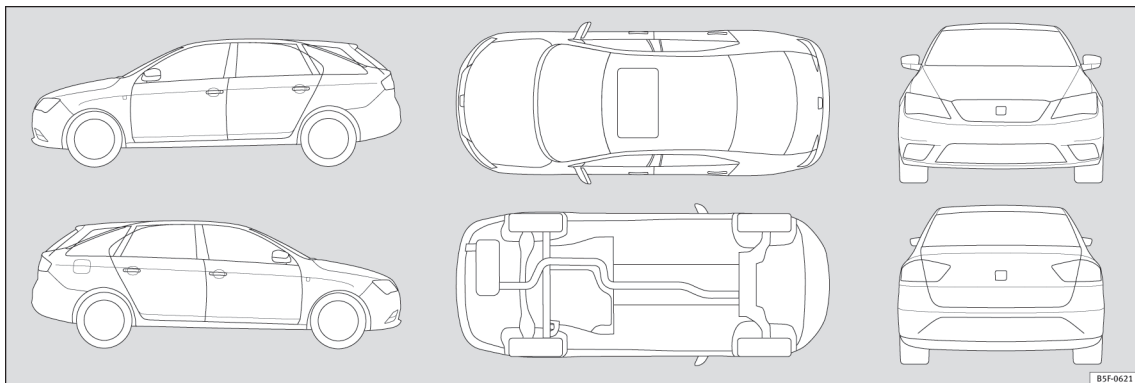

BSF-0621

Fig. 2 For all vehicles and types of bodywork.

Your specialised workshop marks damaged parts in the image with the following symbols:

- × Scratch
- Dent
- Damage to paintwork
- △ Dent from stone

Have any flaws been detected? Yes: No:

Description of flaws:

Technical Service Stamp

Service receipts

	YES	NO
LongLife Service:	<input type="checkbox"/>	<input type="checkbox"/>
Service dependent on time/distance travelled	<input type="checkbox"/>	<input type="checkbox"/>
Oil change service	<input type="checkbox"/>	<input type="checkbox"/>
Inspection	<input type="checkbox"/>	<input type="checkbox"/>
Without oil change	<input type="checkbox"/>	<input type="checkbox"/>
With oil change	<input type="checkbox"/>	<input type="checkbox"/>
Additional jobs:	YES	NO
Dust and pollen filter	<input type="checkbox"/>	<input type="checkbox"/>
Air filter	<input type="checkbox"/>	<input type="checkbox"/>
Fuel filter	<input type="checkbox"/>	<input type="checkbox"/>
Spark plugs	<input type="checkbox"/>	<input type="checkbox"/>
Brake fluid	<input type="checkbox"/>	<input type="checkbox"/>
DSG®: oil and filter	<input type="checkbox"/>	<input type="checkbox"/>
ATF	<input type="checkbox"/>	<input type="checkbox"/>
HALDEX clutch (oil)	<input type="checkbox"/>	<input type="checkbox"/>
Gas filter and hoses	<input type="checkbox"/>	<input type="checkbox"/>
Liquid gas filter (paper filter)	<input type="checkbox"/>	<input type="checkbox"/>
Timing belt	<input type="checkbox"/>	<input type="checkbox"/>

Date:

Km/Miles:

Invoice number:

Repair recommendation:

Service carried out by:

Technical Service Stamp

SEAT Service Mobility

Valid from:

to:

SEAT dealer's stamp

Next Service to be carried out

Date:

Km/Miles:

(whichever is first)

 Note

We recommend that you visit a SEAT Official Service whenever you require any work done on your vehicle. Scrupulously following the Services (oil, inspection) at a SEAT Official Service can increase the value of your vehicle.

Proof of bodywork check (regarding corrosion)

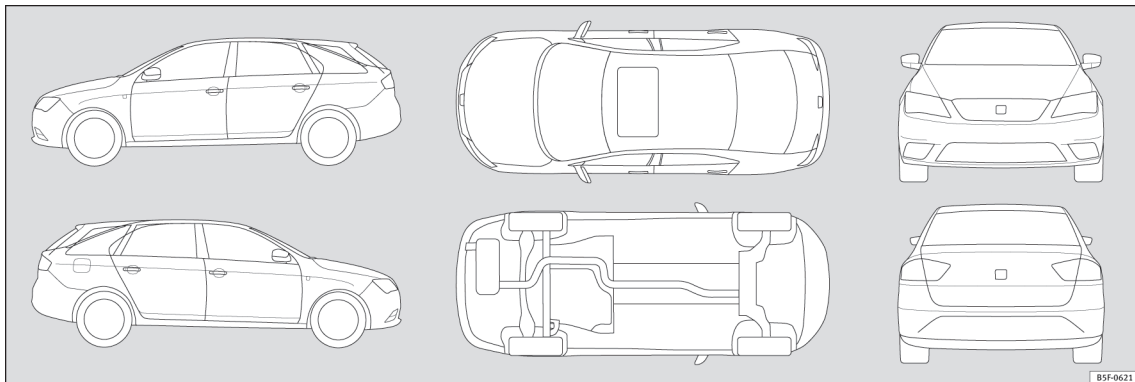

BSF-0621

Fig. 3 For all vehicles and types of bodywork.

Your specialised workshop marks damaged parts in the image with the following symbols:

- × Scratch
- Dent
- Damage to paintwork
- △ Dent from stone

Have any flaws been detected? Yes: No:

Description of flaws:

Technical Service Stamp

Service receipts

	YES	NO
LongLife Service:	<input type="checkbox"/>	<input type="checkbox"/>
Service dependent on time/distance travelled	<input type="checkbox"/>	<input type="checkbox"/>
Oil change service	<input type="checkbox"/>	<input type="checkbox"/>
Inspection	<input type="checkbox"/>	<input type="checkbox"/>
Without oil change	<input type="checkbox"/>	<input type="checkbox"/>
With oil change	<input type="checkbox"/>	<input type="checkbox"/>
Additional jobs:	YES	NO
Dust and pollen filter	<input type="checkbox"/>	<input type="checkbox"/>
Air filter	<input type="checkbox"/>	<input type="checkbox"/>
Fuel filter	<input type="checkbox"/>	<input type="checkbox"/>
Spark plugs	<input type="checkbox"/>	<input type="checkbox"/>
Brake fluid	<input type="checkbox"/>	<input type="checkbox"/>
DSG®: oil and filter	<input type="checkbox"/>	<input type="checkbox"/>
ATF	<input type="checkbox"/>	<input type="checkbox"/>
HALDEX clutch (oil)	<input type="checkbox"/>	<input type="checkbox"/>
Gas filter and hoses	<input type="checkbox"/>	<input type="checkbox"/>
Liquid gas filter (paper filter)	<input type="checkbox"/>	<input type="checkbox"/>
Timing belt	<input type="checkbox"/>	<input type="checkbox"/>

Date:

Km/Miles:

Invoice number:

Repair recommendation:

Service carried out by:

Technical Service Stamp

SEAT Service Mobility

Valid from:

to:

SEAT dealer's stamp

Next Service to be carried out

Date:

Km/Miles:

(whichever is first)

 Note

We recommend that you visit a SEAT Official Service whenever you require any work done on your vehicle. Scrupulously following the Services (oil, inspection) at a SEAT Official Service can increase the value of your vehicle.

Proof of bodywork check (regarding corrosion)

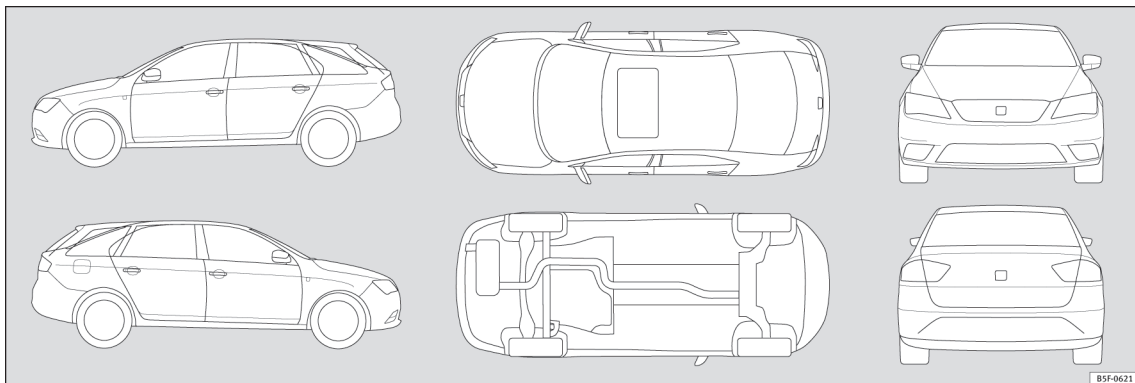

Fig. 4 For all vehicles and types of bodywork.

Your specialised workshop marks damaged parts in the image with the following symbols:

- × Scratch
- Dent
- Damage to paintwork
- △ Dent from stone

Have any flaws been detected?	Yes: <input type="checkbox"/>	No: <input type="checkbox"/>
Description of flaws:		

Technical Service Stamp

Service receipts

	YES	NO
LongLife Service:	<input type="checkbox"/>	<input type="checkbox"/>
Service dependent on time/distance travelled	<input type="checkbox"/>	<input type="checkbox"/>
Oil change service	<input type="checkbox"/>	<input type="checkbox"/>
Inspection	<input type="checkbox"/>	<input type="checkbox"/>
Without oil change	<input type="checkbox"/>	<input type="checkbox"/>
With oil change	<input type="checkbox"/>	<input type="checkbox"/>
Additional jobs:	YES	NO
Dust and pollen filter	<input type="checkbox"/>	<input type="checkbox"/>
Air filter	<input type="checkbox"/>	<input type="checkbox"/>
Fuel filter	<input type="checkbox"/>	<input type="checkbox"/>
Spark plugs	<input type="checkbox"/>	<input type="checkbox"/>
Brake fluid	<input type="checkbox"/>	<input type="checkbox"/>
DSG®: oil and filter	<input type="checkbox"/>	<input type="checkbox"/>
ATF	<input type="checkbox"/>	<input type="checkbox"/>
HALDEX clutch (oil)	<input type="checkbox"/>	<input type="checkbox"/>
Gas filter and hoses	<input type="checkbox"/>	<input type="checkbox"/>
Liquid gas filter (paper filter)	<input type="checkbox"/>	<input type="checkbox"/>
Timing belt	<input type="checkbox"/>	<input type="checkbox"/>

Date:

Km/Miles:

Invoice number:

Repair recommendation:

Service carried out by:

Technical Service Stamp

SEAT Service Mobility

Valid from:

to:

SEAT dealer's stamp

Next Service to be carried out

Date:

Km/Miles:

(whichever is first)

 Note

We recommend that you visit a SEAT Official Service whenever you require any work done on your vehicle. Scrupulously following the Services (oil, inspection) at a SEAT Official Service can increase the value of your vehicle.

Proof of bodywork check (regarding corrosion)

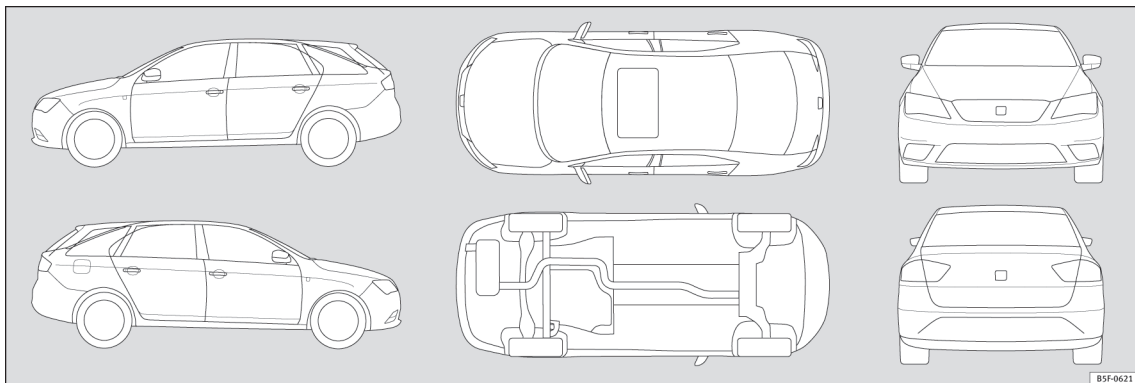

BSF-0621

Fig. 5 For all vehicles and types of bodywork.

Your specialised workshop marks damaged parts in the image with the following symbols:

- × Scratch
- Dent
- Damage to paintwork
- △ Dent from stone

Have any flaws been detected? Yes: No:

Description of flaws:

Technical Service Stamp

Service receipts

	YES	NO
LongLife Service:	<input type="checkbox"/>	<input type="checkbox"/>
Service dependent on time/distance travelled	<input type="checkbox"/>	<input type="checkbox"/>
Oil change service	<input type="checkbox"/>	<input type="checkbox"/>
Inspection	<input type="checkbox"/>	<input type="checkbox"/>
Without oil change	<input type="checkbox"/>	<input type="checkbox"/>
With oil change	<input type="checkbox"/>	<input type="checkbox"/>
Additional jobs:	YES	NO
Dust and pollen filter	<input type="checkbox"/>	<input type="checkbox"/>
Air filter	<input type="checkbox"/>	<input type="checkbox"/>
Fuel filter	<input type="checkbox"/>	<input type="checkbox"/>
Spark plugs	<input type="checkbox"/>	<input type="checkbox"/>
Brake fluid	<input type="checkbox"/>	<input type="checkbox"/>
DSG®: oil and filter	<input type="checkbox"/>	<input type="checkbox"/>
ATF	<input type="checkbox"/>	<input type="checkbox"/>
HALDEX clutch (oil)	<input type="checkbox"/>	<input type="checkbox"/>
Gas filter and hoses	<input type="checkbox"/>	<input type="checkbox"/>
Liquid gas filter (paper filter)	<input type="checkbox"/>	<input type="checkbox"/>
Timing belt	<input type="checkbox"/>	<input type="checkbox"/>

Date:

Km/Miles:

Invoice number:

Repair recommendation:

Service carried out by:

Technical Service Stamp

SEAT Service Mobility

Valid from:

to:

SEAT dealer's stamp

Next Service to be carried out

Date:

Km/Miles:

(whichever is first)

 Note

We recommend that you visit a SEAT Official Service whenever you require any work done on your vehicle. Scrupulously following the Services (oil, inspection) at a SEAT Official Service can increase the value of your vehicle.

Proof of bodywork check (regarding corrosion)

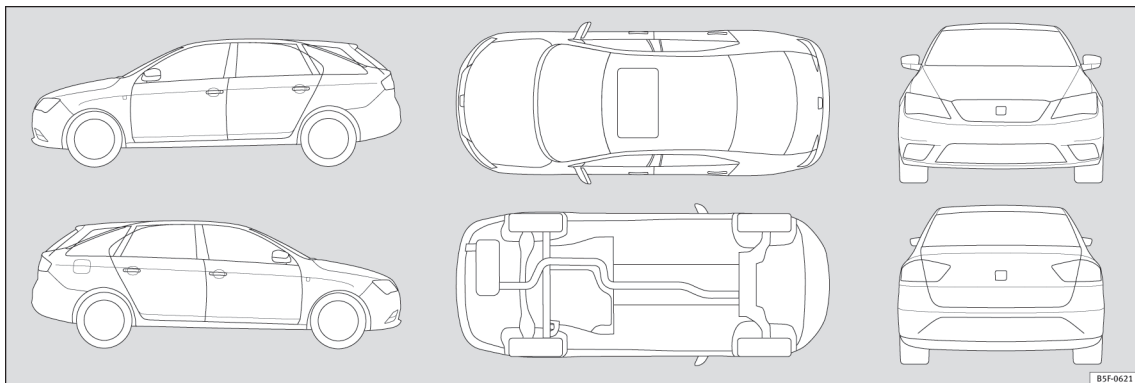

BSF-0621

Fig. 6 For all vehicles and types of bodywork.

Your specialised workshop marks damaged parts in the image with the following symbols:

- × Scratch
- Dent
- Damage to paintwork
- △ Dent from stone

Have any flaws been detected?

Yes:

No:

Description of flaws:

Technical Service Stamp

Service receipts

	YES	NO
LongLife Service:	<input type="checkbox"/>	<input type="checkbox"/>
Service dependent on time/distance travelled	<input type="checkbox"/>	<input type="checkbox"/>
Oil change service	<input type="checkbox"/>	<input type="checkbox"/>
Inspection	<input type="checkbox"/>	<input type="checkbox"/>
Without oil change	<input type="checkbox"/>	<input type="checkbox"/>
With oil change	<input type="checkbox"/>	<input type="checkbox"/>
Additional jobs:	YES	NO
Dust and pollen filter	<input type="checkbox"/>	<input type="checkbox"/>
Air filter	<input type="checkbox"/>	<input type="checkbox"/>
Fuel filter	<input type="checkbox"/>	<input type="checkbox"/>
Spark plugs	<input type="checkbox"/>	<input type="checkbox"/>
Brake fluid	<input type="checkbox"/>	<input type="checkbox"/>
DSG®: oil and filter	<input type="checkbox"/>	<input type="checkbox"/>
ATF	<input type="checkbox"/>	<input type="checkbox"/>
HALDEX clutch (oil)	<input type="checkbox"/>	<input type="checkbox"/>
Gas filter and hoses	<input type="checkbox"/>	<input type="checkbox"/>
Liquid gas filter (paper filter)	<input type="checkbox"/>	<input type="checkbox"/>
Timing belt	<input type="checkbox"/>	<input type="checkbox"/>

Date:

Km/Miles:

Invoice number:

Repair recommendation:

Service carried out by:

Technical Service Stamp

SEAT Service Mobility

Valid from:

to:

SEAT dealer's stamp

Next Service to be carried out

Date:

Km/Miles:

(whichever is first)

 Note

We recommend that you visit a SEAT Official Service whenever you require any work done on your vehicle. Scrupulously following the Services (oil, inspection) at a SEAT Official Service can increase the value of your vehicle.

Proof of bodywork check (regarding corrosion)

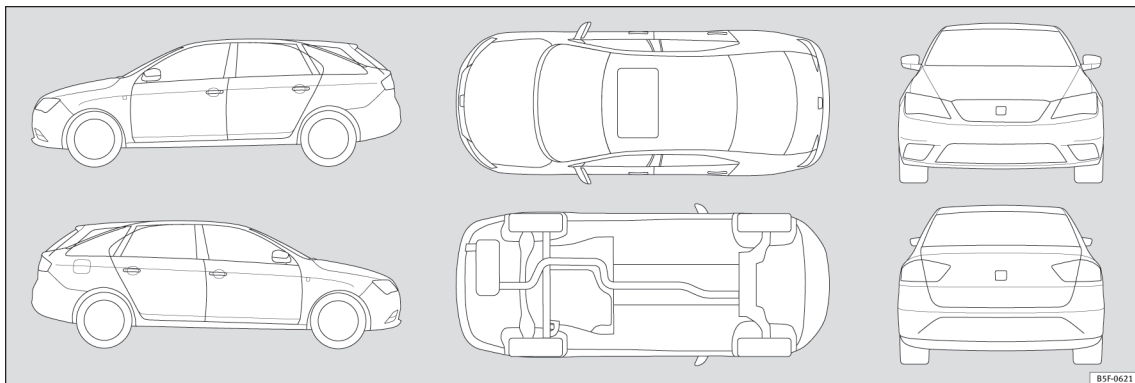

BSF-0621

Fig. 7 For all vehicles and types of bodywork.

Your specialised workshop marks damaged parts in the image with the following symbols:

- × Scratch
- Dent
- Damage to paintwork
- △ Dent from stone

Have any flaws been detected? Yes: No:

Description of flaws:

Technical Service Stamp

Service receipts

	YES	NO
LongLife Service:	<input type="checkbox"/>	<input type="checkbox"/>
Service dependent on time/distance travelled	<input type="checkbox"/>	<input type="checkbox"/>
Oil change service	<input type="checkbox"/>	<input type="checkbox"/>
Inspection	<input type="checkbox"/>	<input type="checkbox"/>
Without oil change	<input type="checkbox"/>	<input type="checkbox"/>
With oil change	<input type="checkbox"/>	<input type="checkbox"/>
Additional jobs:	YES	NO
Dust and pollen filter	<input type="checkbox"/>	<input type="checkbox"/>
Air filter	<input type="checkbox"/>	<input type="checkbox"/>
Fuel filter	<input type="checkbox"/>	<input type="checkbox"/>
Spark plugs	<input type="checkbox"/>	<input type="checkbox"/>
Brake fluid	<input type="checkbox"/>	<input type="checkbox"/>
DSG®: oil and filter	<input type="checkbox"/>	<input type="checkbox"/>
ATF	<input type="checkbox"/>	<input type="checkbox"/>
HALDEX clutch (oil)	<input type="checkbox"/>	<input type="checkbox"/>
Gas filter and hoses	<input type="checkbox"/>	<input type="checkbox"/>
Liquid gas filter (paper filter)	<input type="checkbox"/>	<input type="checkbox"/>
Timing belt	<input type="checkbox"/>	<input type="checkbox"/>

Date:

Km/Miles:

Invoice number:

Repair recommendation:

Service carried out by:

Technical Service Stamp

SEAT Service Mobility

Valid from:

to:

SEAT dealer's stamp

Next Service to be carried out

Date:

Km/Miles:

(whichever is first)



Note

We recommend that you visit a SEAT Official Service whenever you require any work done on your vehicle. Scrupulously following the Services (oil, inspection) at a SEAT Official Service can increase the value of your vehicle.

Proof of bodywork check (regarding corrosion)

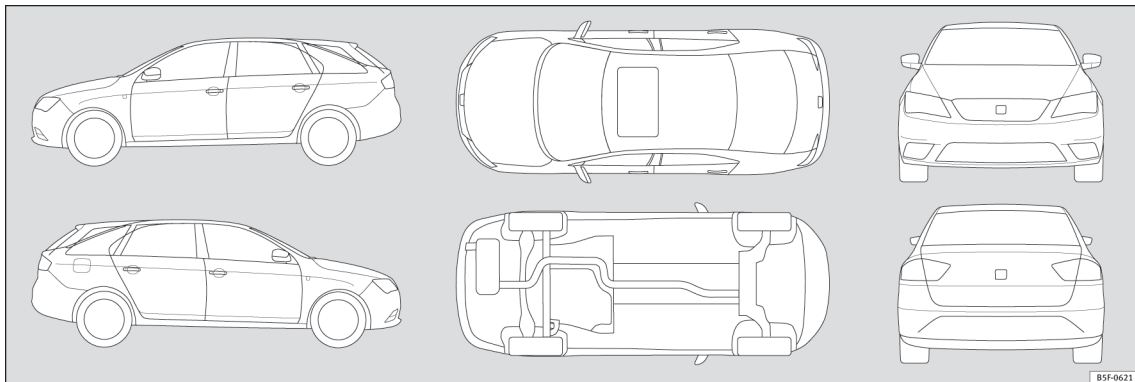

BSF-0621

Fig. 8 For all vehicles and types of bodywork.

Your specialised workshop marks damaged parts in the image with the following symbols:

- × Scratch
- Dent
- Damage to paintwork
- △ Dent from stone

Have any flaws been detected? Yes: No:

Description of flaws:

Technical Service Stamp

Service receipts

	YES	NO
LongLife Service:	<input type="checkbox"/>	<input type="checkbox"/>
Service dependent on time/distance travelled	<input type="checkbox"/>	<input type="checkbox"/>
Oil change service	<input type="checkbox"/>	<input type="checkbox"/>
Inspection	<input type="checkbox"/>	<input type="checkbox"/>
Without oil change	<input type="checkbox"/>	<input type="checkbox"/>
With oil change	<input type="checkbox"/>	<input type="checkbox"/>
Additional jobs:	YES	NO
Dust and pollen filter	<input type="checkbox"/>	<input type="checkbox"/>
Air filter	<input type="checkbox"/>	<input type="checkbox"/>
Fuel filter	<input type="checkbox"/>	<input type="checkbox"/>
Spark plugs	<input type="checkbox"/>	<input type="checkbox"/>
Brake fluid	<input type="checkbox"/>	<input type="checkbox"/>
DSG®: oil and filter	<input type="checkbox"/>	<input type="checkbox"/>
ATF	<input type="checkbox"/>	<input type="checkbox"/>
HALDEX clutch (oil)	<input type="checkbox"/>	<input type="checkbox"/>
Gas filter and hoses	<input type="checkbox"/>	<input type="checkbox"/>
Liquid gas filter (paper filter)	<input type="checkbox"/>	<input type="checkbox"/>
Timing belt	<input type="checkbox"/>	<input type="checkbox"/>

Date:

Km/Miles:

Invoice number:

Repair recommendation:

Service carried out by:

Technical Service Stamp

SEAT Service Mobility

Valid from:

to:

SEAT dealer's stamp

Next Service to be carried out

Date:

Km/Miles:

(whichever is first)

 Note

We recommend that you visit a SEAT Official Service whenever you require any work done on your vehicle. Scrupulously following the Services (oil, inspection) at a SEAT Official Service can increase the value of your vehicle.

Proof of bodywork check (regarding corrosion)

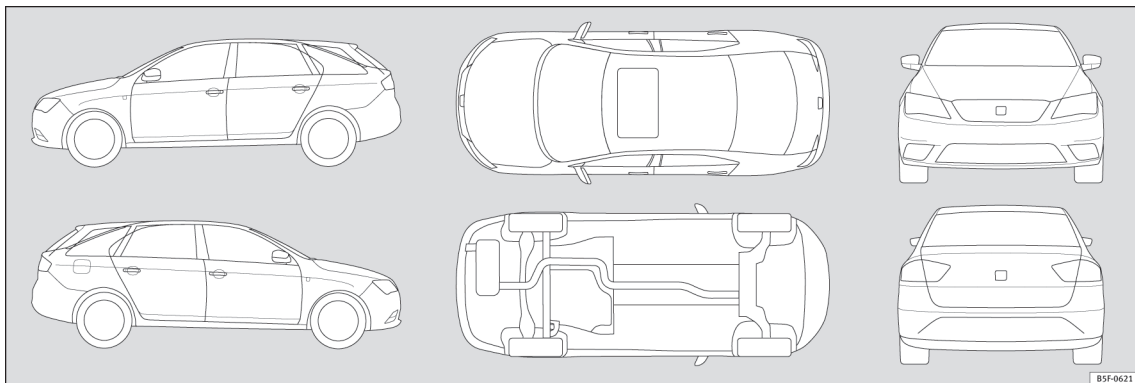

BSF-0621

Fig. 9 For all vehicles and types of bodywork.

Your specialised workshop marks damaged parts in the image with the following symbols:

- × Scratch
- Dent
- Damage to paintwork
- △ Dent from stone

Have any flaws been detected? Yes: No:

Description of flaws:

Technical Service Stamp

Service receipts

	YES	NO
LongLife Service:	<input type="checkbox"/>	<input type="checkbox"/>
Service dependent on time/distance travelled	<input type="checkbox"/>	<input type="checkbox"/>
Oil change service	<input type="checkbox"/>	<input type="checkbox"/>
Inspection	<input type="checkbox"/>	<input type="checkbox"/>
Without oil change	<input type="checkbox"/>	<input type="checkbox"/>
With oil change	<input type="checkbox"/>	<input type="checkbox"/>
Additional jobs:	YES	NO
Dust and pollen filter	<input type="checkbox"/>	<input type="checkbox"/>
Air filter	<input type="checkbox"/>	<input type="checkbox"/>
Fuel filter	<input type="checkbox"/>	<input type="checkbox"/>
Spark plugs	<input type="checkbox"/>	<input type="checkbox"/>
Brake fluid	<input type="checkbox"/>	<input type="checkbox"/>
DSG®: oil and filter	<input type="checkbox"/>	<input type="checkbox"/>
ATF	<input type="checkbox"/>	<input type="checkbox"/>
HALDEX clutch (oil)	<input type="checkbox"/>	<input type="checkbox"/>
Gas filter and hoses	<input type="checkbox"/>	<input type="checkbox"/>
Liquid gas filter (paper filter)	<input type="checkbox"/>	<input type="checkbox"/>
Timing belt	<input type="checkbox"/>	<input type="checkbox"/>

Date:

Km/Miles:

Invoice number:

Repair recommendation:

Service carried out by:

Technical Service Stamp

SEAT Service Mobility

Valid from:

to:

SEAT dealer's stamp

Next Service to be carried out

Date:

Km/Miles:

(whichever is first)

 Note

We recommend that you visit a SEAT Official Service whenever you require any work done on your vehicle. Scrupulously following the Services (oil, inspection) at a SEAT Official Service can increase the value of your vehicle.

Proof of bodywork check (regarding corrosion)

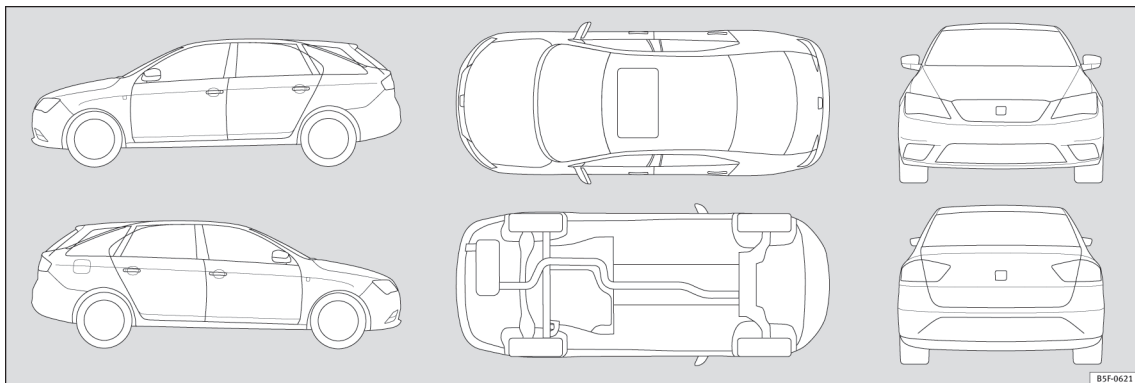

BSF-0621

Fig. 10 For all vehicles and types of bodywork.

Your specialised workshop marks damaged parts in the image with the following symbols:

- × Scratch
- Dent
- Damage to paintwork
- △ Dent from stone

Have any flaws been detected? Yes: No:

Description of flaws:

Technical Service Stamp

Service receipts

	YES	NO
LongLife Service:	<input type="checkbox"/>	<input type="checkbox"/>
Service dependent on time/distance travelled	<input type="checkbox"/>	<input type="checkbox"/>
Oil change service	<input type="checkbox"/>	<input type="checkbox"/>
Inspection	<input type="checkbox"/>	<input type="checkbox"/>
Without oil change	<input type="checkbox"/>	<input type="checkbox"/>
With oil change	<input type="checkbox"/>	<input type="checkbox"/>
Additional jobs:	YES	NO
Dust and pollen filter	<input type="checkbox"/>	<input type="checkbox"/>
Air filter	<input type="checkbox"/>	<input type="checkbox"/>
Fuel filter	<input type="checkbox"/>	<input type="checkbox"/>
Spark plugs	<input type="checkbox"/>	<input type="checkbox"/>
Brake fluid	<input type="checkbox"/>	<input type="checkbox"/>
DSG®: oil and filter	<input type="checkbox"/>	<input type="checkbox"/>
ATF	<input type="checkbox"/>	<input type="checkbox"/>
HALDEX clutch (oil)	<input type="checkbox"/>	<input type="checkbox"/>
Gas filter and hoses	<input type="checkbox"/>	<input type="checkbox"/>
Liquid gas filter (paper filter)	<input type="checkbox"/>	<input type="checkbox"/>
Timing belt	<input type="checkbox"/>	<input type="checkbox"/>

Date:

Km/Miles:

Invoice number:

Repair recommendation:

Service carried out by:

Technical Service Stamp

SEAT Service Mobility

Valid from:

to:

SEAT dealer's stamp

Next Service to be carried out

Date:

Km/Miles:

(whichever is first)



Note

We recommend that you visit a SEAT Official Service whenever you require any work done on your vehicle. Scrupulously following the Services (oil, inspection) at a SEAT Official Service can increase the value of your vehicle.

Proof of bodywork check (regarding corrosion)

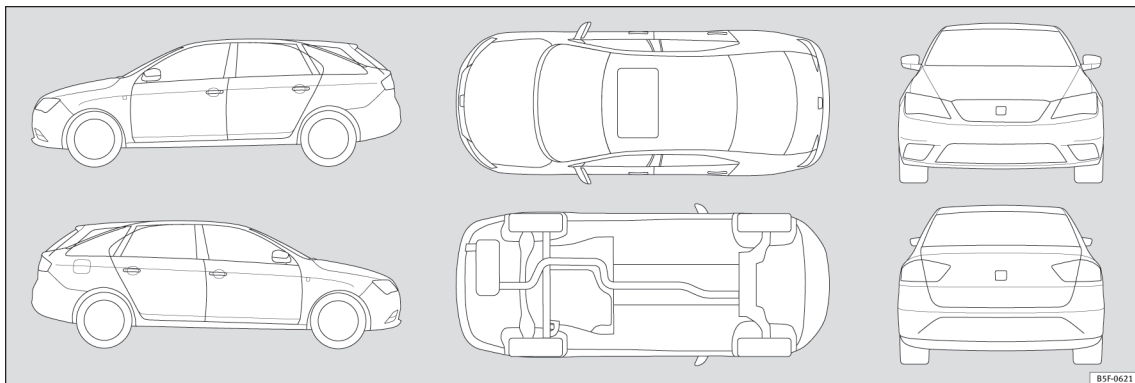

BSF-0621

Fig. 11 For all vehicles and types of bodywork.

Your specialised workshop marks damaged parts in the image with the following symbols:

- × Scratch
- Dent
- Damage to paintwork
- △ Dent from stone

Have any flaws been detected? Yes: No:

Description of flaws:

Technical Service Stamp

Other notes from the Technical Service

Notes

Km/Miles: Date: Observations:	Technical Service Stamp
Km/Miles: Date: Observations:	Technical Service Stamp
Km/Miles: Date: Observations:	Technical Service Stamp

Notes

Km/Miles: Date: Observations:	Technical Service Stamp
Km/Miles: Date: Observations:	Technical Service Stamp
Km/Miles: Date: Observations:	Technical Service Stamp

Notes

Km/Miles: Date: Observations:	Technical Service Stamp
Km/Miles: Date: Observations:	Technical Service Stamp
Km/Miles: Date: Observations:	Technical Service Stamp

SEAT S.A. is permanently concerned about continuous development of its types and models. For this reason we ask you to understand, that at any given time, changes regarding shape, equipment and technique may take place on the car delivered. For this reason no right at all may derive based on the data, drawings and descriptions in this current handbook.

All texts, illustrations and standards in this handbook are based on the status of information at the time of printing. Except for error or omission, the information included in the current handbook is valid as of the date of closing print.

Re-printing, copying or translating, whether total or partial is not allowed unless SEAT allows it in written form.

SEAT reserves all rights in accordance with the "Copyright" Act.

All rights on changes are reserved.

 This paper has been manufactured using bleached non-chlorine cellulose.

© SEAT S.A. - Reprint: 15.11.15

Inglés 5F0012720SD (11.15) (GT9)



5F0012720SD



SEAT recommends
SEAT **GENUINE OIL**



SEAT recommends
Castrol EDGE Professional